

Ansicht Skimmerseite - Prospetto parte skimmer

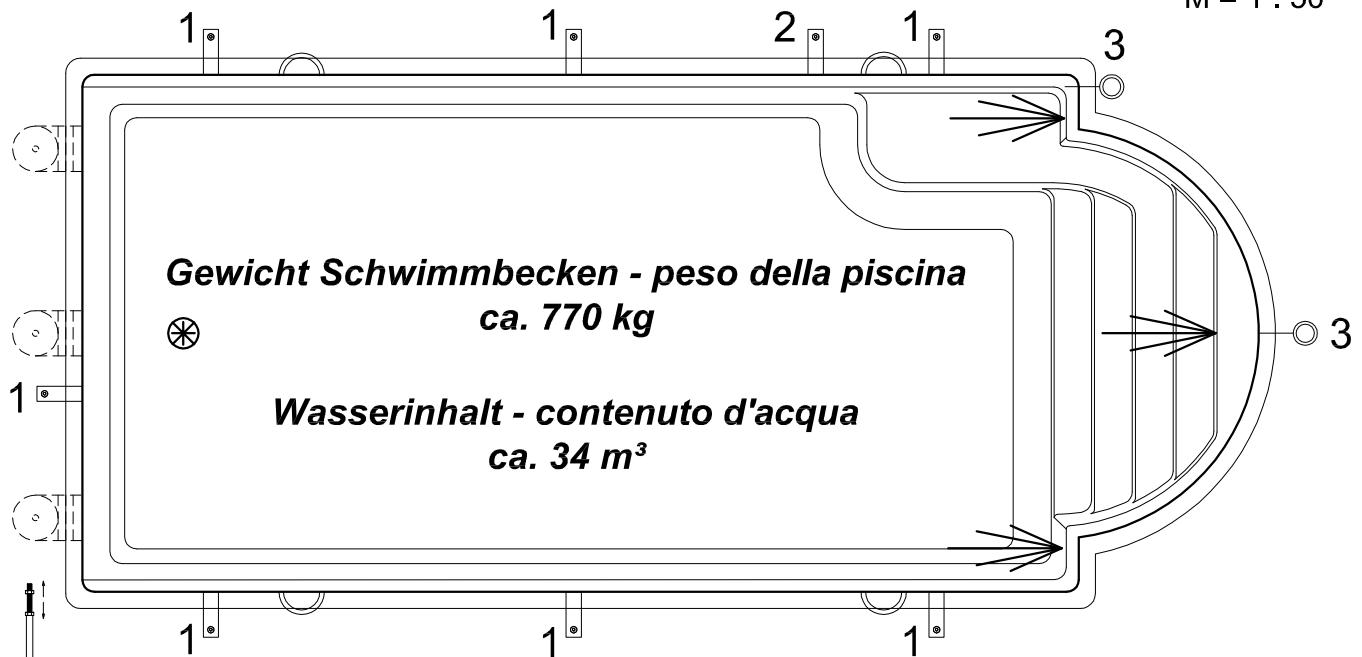

Gewicht Schwimmbecken - peso della piscina
ca. 770 kg

Wasserinhalt - contenuto d'acqua
ca. 34 m³

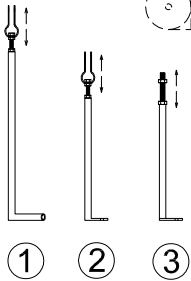

1 = Beckenstützen seitlich / tiranti laterali

2 = Beckenstützen vertikal (Zugstange) / tiranti verticale

3 = Beckenstützen vertikal M20 Druckstange / tiranti a pressione verticale M20

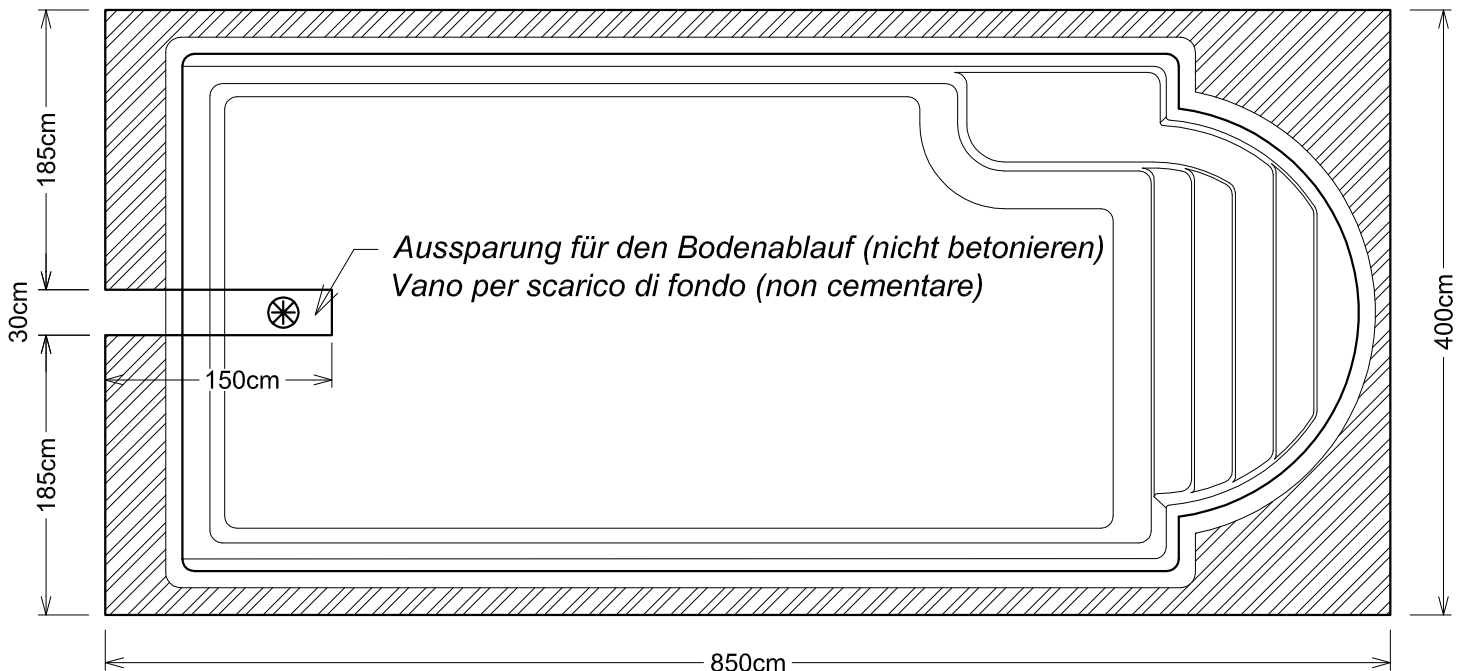

Aussparung für den Bodenablauf (nicht betonieren)
Vano per scarico di fondo (non cementare)

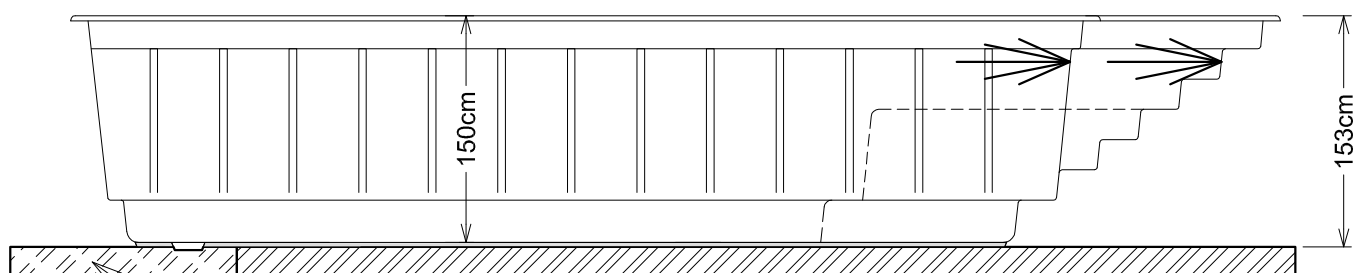

Fundamentplatte armiert laut örtlichen Bodenverhältnissen
Soletta di cemento armato secondo la solidità del terreno