

MIDA.Boost 20

Art. 2672

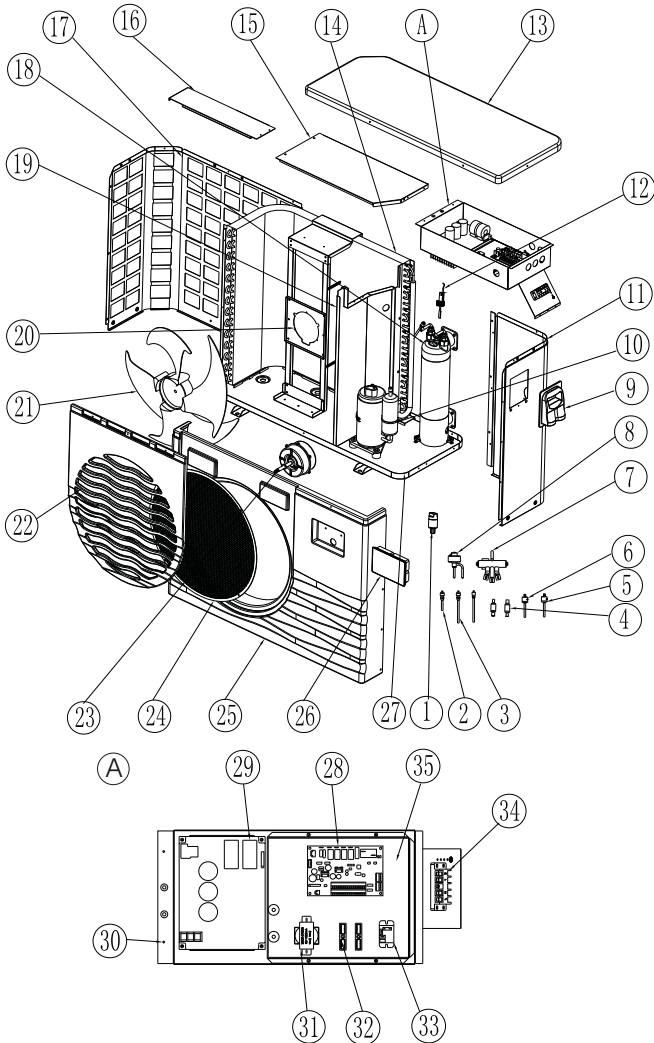

Beschreibung	Art. Nr.
pressure sensor	2672-E1
Needle	2672-E2
Needle	2672-E3
Filter	2672-E4
pressure switch	2672-E5
pressure switch	2672-E6
4-way Valve and fittings	2672-E7
Electronic Expansion Valve	2672-E8
electronic box	2672-E9
compressor	2672-E10
right panel	2672-E11
flow switch	2672-E12
top cover	2672-E13
heat exchanger	2672-E14
Electrical Box Cover	2672-E15
Supporting Plate	2672-E16
back protection net	2672-E17
titanium heat exchanger	2672-E18
Middle Plate	2672-E19
Fan Motor Support	2672-E20
Fan Blade	2672-E21
Fan Guard	2672-E22
fan motor	2672-E23
fan protection net	2672-E24
Front Plate	2672-E25
Colorful display	2672-E26
Chassis	2672-E27
PC1002	2672-E28
Inverter drive module	2672-E29
Electrical Box	2672-E30
Power Transformer	2672-E31
Terminal Board (2 bit)	2672-E32
Relay	2672-E33
Terminal Board (5 bit)	2672-E34
scale board	2672-E35